

# Signet 9900 Transmitter

Member of the SmartPro™ Family of Instruments



Panel Mount



Field Mount

The Signet 9900 Transmitter provides a single channel interface for many different parameters including Flow, pH/ORP, Conductivity/Resistivity, Salinity, Pressure, Temperature, Level and other sensors that output a 4 to 20 mA signal. The extra large (3.90" x 3.90") auto-sensing backlit display features "at-a-glance" visibility that can be viewed at 4-5 times the distance over traditional transmitters. The highly illuminated display and large characters reduce the risk of misreading or misinterpreting the displayed values. The display shows separate lines for units, main and secondary measurements as well as a "dial-type" digital bar graph.

The 9900 is offered in both panel or field mount versions. Both configurations can run on 12 to 32 VDC power (24 VDC nominal). The 9900 can also be loop powered with compatible sensors.

Designed for complete flexibility, plug-in modules allow the unit to easily adapt to meet changing customer needs. Optional modules include Relay, Direct Conductivity/Resistivity, H COMM and a PC COMM configuration tool. The unit can be used with default values for quick and easy programming or can be customized with labeling, adjustable minimum and maximum dial settings, and unit and decimal measurement choices.

## Features

- Multi-Parameter input selection
- Large auto-sensing backlit display with "at a glance" visibility
- "Dial-type" digital bar graph
- Intuitive and "user-friendly" interface consistent with legacy Signet ProPoint® and ProcessPro® devices
- Optional field upgradable relays
- Selectable error mode for current outputs, 3.6 mA or 22 mA
- 4 to 20 mA input (with optional 8058 Signal Converter)
- Warning LED indicator
- Custom 13-character label capabilities for the channel type
- Factory reset capability
- Optional PC COMM configuration tool
- Optional H COMM module for two-way communication



## Applications

- Wastewater Treatment
- Reverse Osmosis
- Deionization
  - Ultra Pure Water
  - Two Bed System
  - Mixed Bed System
- Chemical Manufacturing/Addition
- Metal and Plastic Finishing
- Fume Scrubber
- Cooling Towers
- Media Filtration

# Specifications

General			
Input Channels	One		
Input Types	Digital (S <sup>3</sup> L)	Serial ASCII, TTL level, 9600 bps	
	Frequency	Range	0.5 to 1500 Hz
		Accuracy	0.5% of reading
Measurement Types	Flow, pH/ORP, Conductivity/Resistivity, Salinity, Pressure, Temperature, Level or user-defined (via 8058)		
Enclosure and Display			
Case Material	PBT		
Window	Shatter-resistant glass		
Keypad	4 buttons, injection-molded silicone rubber seal		
Display	Backlit, 7 and 14-segment		
Update Rate	1 s		
LCD Contrast	5 settings		
Indicators	"Dial-type" digital bar graph. LEDs for Open Collector, Relays and Warning Indicator		
Enclosure Size	¼ DIN		
Mounting	Panel	¼ DIN, ribbed on four sides for panel mounting clip inside panel, silicon gasket included	
	Field	Mounts to standard Signet field mount junction boxes. Optional angle adjustment adapter available.	
	Wall	Large enclosure (sold as an accessory) that encases the panel mount transmitter	
Display Ranges			
pH	0.00 to 15.00 pH		
pH Temperature	-99 °C to 350 °C	-146 °F to 662 °F	
ORP	-1999 to 1999.9 mV		
Flow Rate	-9999 to 99999 units per second, minute, hour or day		
Totalizer	0.00 to 99999999 units		
Conductivity	0.0000 to 99999 µS, mS, PPM and PPB (TDS), kΩ, MΩ		
Conductivity Temperature	-99 °C to 350 °C	-146 °F to 662 °F	
Temperature	-99 °C to 350 °C	-146 °F to 662 °F	
Pressure	-40 to 1000 psi		
Level	-9999 to 99999 m, cm, ft, in, %		
Volume	0 to 99999 cm <sup>3</sup> , m <sup>3</sup> , in <sup>3</sup> , ft <sup>3</sup> , gal, L, lb, kg, %		
Salinity	0 to 100 PPT		
Environmental			
Ambient Operating Temperature			
Backlit LCD	-10 °C to 70 °C	14 °F to 158 °F	
Storage Temperature	-15 °C to 70 °C	5 °F to 158 °F	
Relative Humidity	0 to 100% condensing for field mount; 0 to 95% non-condensing for panel mount		
Maximum Altitude	4,000 m (13,123 ft)		
Enclosure Rating	Designed to meet NEMA 4X/IP65 (front face only on panel mount); field mount is 100% NEMA 4X/IP65		

## Specifications (continued)

### Electrical Requirements

Power to Sensors

Voltage	+4.9 to 5.5 VDC @ 25 °C, regulated
Current	1.5 mA max in loop power mode (up to 2.0 mA with 24 V @ 300 Ω max. loop impedance); 20 mA max when using DC power
Short Circuit	Protected
Isolation	Low voltage (< 48V AC/DC) to loop with DC power connected

No isolation when using loop power only

Terminal Blocks	Pluggable screw type	14 AWG max wire gauge
-----------------	----------------------	-----------------------

### Input Power

DC	12 to 32 VDC ±10%, regulated
Overvoltage Protection	48 Volt Transient Protection Device

Current limiting for circuit protection

Reverse-Voltage Protection

### Loop Power

No DC Power Input

Max. Loop Impedance	50 Ω @ 12 V	325 Ω @ 18 V	600 Ω @ 24 V
---------------------	-------------	--------------	--------------

With DC Power Input

Max. Loop Impedance	250 Ω @ 12 V	500 Ω @ 18 V	750 Ω @ 24 V
---------------------	--------------	--------------	--------------

### Relay Specifications

<b>Dry-Contact Relays</b>	2	<b>Open Collector</b>	1
---------------------------	---	-----------------------	---

Type	SPDT	N/A
Form	C	N/A

Max. Current Rating	5 A resistive	50 mA DC
---------------------	---------------	----------

Max. Voltage Rating	30 VDC or 250 VAC	30 VDC
---------------------	-------------------	--------

Hysteresis	Adjustable (absolute in engineering units) (EUs)
------------	--

Latch	Reset in test screen only
-------	---------------------------

Delay	9999.9 seconds (max.)
-------	-----------------------

Test Mode	Set On or Off
-----------	---------------

Cycle Time	99999 seconds (max.)
------------	----------------------

Maximum Pulse Rate	400 pulses/minute
--------------------	-------------------

Proportional Pulse	400 pulses/minute
--------------------	-------------------

Volumetric Pulse Width	0.1 to 3200 s
------------------------	---------------

Pulse Width Modulation	0.1 to 320 s
------------------------	--------------

### Input Types

Digital (S<sup>3</sup>L) or AC frequency

4 to 20 mA input via the 8058

pH/ORP input via the Digital (S<sup>3</sup>L) output from the 2750 pH/ORP Sensor Electronics

Raw Conductivity/Resistivity input directly from Signet Conductivity/Resistivity electrodes via Direct Conductivity/Resistivity Module or via 2850

### Input Specifications

Digital (S <sup>3</sup> L)	Serial ACSII, TTL level, 9600 bps
----------------------------	-----------------------------------

Frequency Input

Sensitivity	80 mV @ 5 Hz, gradually increasing with frequency
-------------	---

Span	0.5 Hz to 1500 Hz @ TTL level input
------	-------------------------------------

Accuracy	± 0.5% or reading max error @ 25 °C
----------	-------------------------------------

Resolution	1 μS
------------	------

Repeatability	± 0.2% of reading
---------------	-------------------

## Specifications (continued)

### Input Specifications continued

#### Power Supply

Rejection	$\pm 1 \mu\text{A}$ per volt
Short Circuit	Protected
Update Rate	$(1/\text{frequency}) + 150 \text{ ms}$

### Output Specifications

#### Current Output

Current Loop Output Standard	ANSI-ISA 50.00.01 Class H		
Current Output	4 to 20 mA, isolated, fully adjustable and reversible		
Span	3.8 to 21 mA		
Zero	4.0 mA factory set; user programmable from 3.8 to 5.0 mA		
Full Scale	20.00 mA factory set; user programmable from 19.0 to 21.0 mA		
Accuracy	$\pm 32 \mu\text{A}$ max. error @ 25 °C @ 24 VDC		
Resolution	6 $\mu\text{A}$ or better		
Temperature Drift	$\pm 1 \mu\text{A}$ per °C		
Power Supply Rejection	$\pm 1 \mu\text{A}$ per V		
Isolation	Low voltage (< 48 VAC/DC)		
Voltage	12 to 32 VDC $\pm 10\%$		
Max. Impedance (with DC power input)	250 $\Omega$ @ 12 VDC	500 $\Omega$ @ 18 VDC	750 $\Omega$ @ 24 VDC
Max. Impedance (no DC power input)	50 $\Omega$ @ 12 VDC	325 $\Omega$ @ 18 VDC	600 $\Omega$ @ 24 VDC
Update Rate	150 mS nominal		
Short circuit and reverse polarity protected			
Adjustable Span	Reversible		
Error Condition	Selectable error condition 3.6 or 22 mA		
Actual update rate determined by sensor type			
Test Mode	Increment to desired current (range 3.8 to 21.00 mA)		
Open Collector Output	50 mA DC max., 30 VDC		

### Shipping Weights

Base Unit	0.63 kg	1.38 lb
H COMM Module	0.16 kg	0.35 lb
Conductivity Module	0.16 kg	0.35 lb
Relay Module	0.19 kg	0.41 lb

### Standards and Approvals

CE, UL, CUL





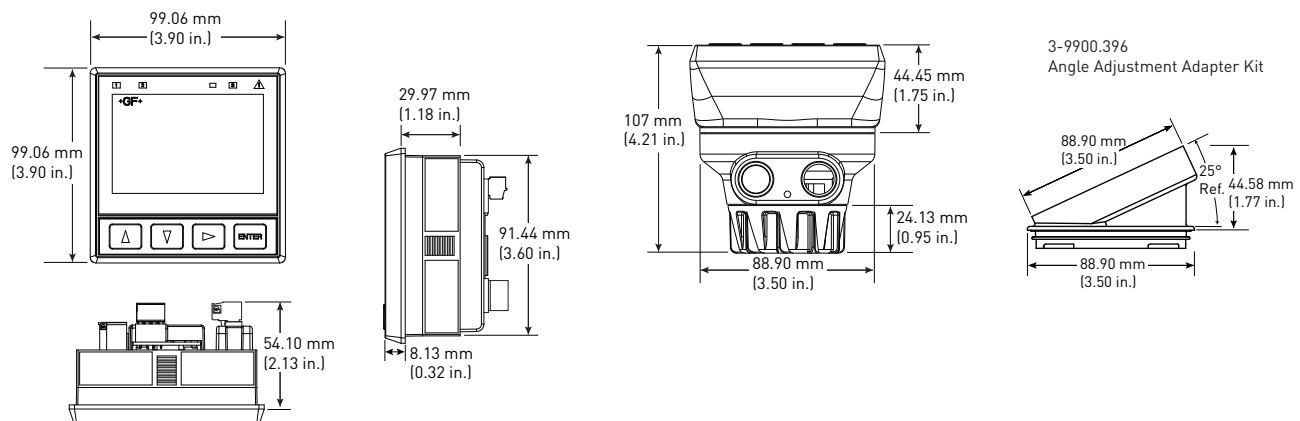

RoHS Compliant, China RoHS

Manufactured under ISO 9001 and ISO 14001 for Environmental Management

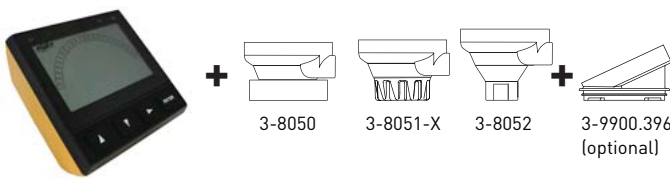
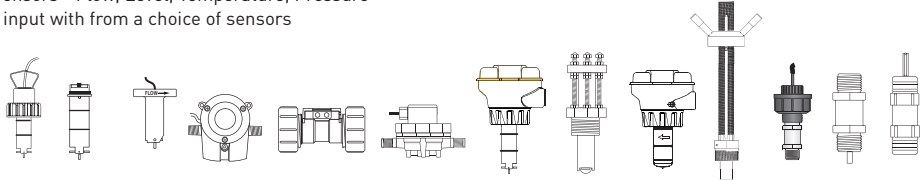
## Dimensions

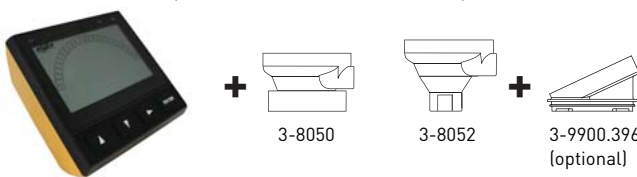
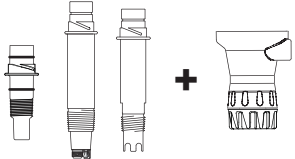
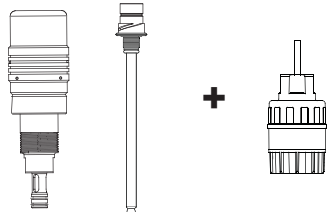

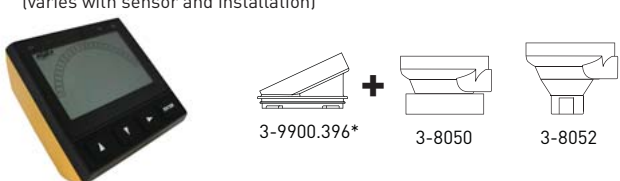
# System Overview

<p><b>Panel Mount</b></p> <p><b>Signet Model 9900 Transmitter</b> (Includes mounting bracket and panel gasket)</p> 	<p><b>Field Mount - Pipe, Tank, Wall</b></p> <p><b>Signet Model 9900 Transmitter</b> with Junction Box (varies with sensor and installation)</p>  <p>3-8050    3-8051-X    3-8052    3-9900.396 (optional)</p>
<p>Signet Sensors - Flow, Level, Temperature, Pressure use one input with from a choice of sensors</p>  <p>515    8510    525    2000    2100    2507    2537    2540    2551    2552    2250    2350    2450 2536    8512</p>	
<p>Signet Fittings - See individual sensor data sheets <span style="float: right;">All sold separately</span></p>	
<p><b>Panel Mount</b></p> <p><b>Signet Model 9900 Transmitter</b> (Includes mounting bracket and panel gasket)</p> 	<p><b>Field Mount - Pipe, Tank, Wall</b></p> <p><b>Signet Model 9900 Transmitter</b> with Junction Box (varies with sensor and installation)</p>  <p>3-8050    3-8052    3-9900.396 (optional)</p>
<p>Signet Sensors - pH/ORP use one input from a choice of sensors With 2750 Sensor Electronics</p> 	<p>Signet Wet-Tap Electrode Model 2756, 2757 and 3719 Wet-Tap with 2750 Sensor Electronics</p> 
<p>Signet Fittings - See individual sensor data sheets <span style="float: right;">All sold separately</span></p>	
<p><b>Panel Mount</b></p> <p><b>Signet Model 9900 Transmitter</b> (Includes mounting bracket and panel gasket)</p> 	<p><b>Field Mount - Pipe, Tank, Wall</b></p> <p><b>Signet Model 9900 Transmitter</b> with 3-9900.396 Angle Adapter and Junction Box (varies with sensor and installation)</p>  <p>3-9900.396*    3-8050    3-8052</p>
<p>Signet Sensors - Conductivity/Resistivity and Salinity Electrodes use one input from a choice of electrodes with Conductivity Module or 2850 Sensor Electronics</p> 	
<p>Signet Fittings - See individual sensor data sheets <span style="float: right;">All sold separately</span></p>	

\*3-9900.396 is required with the Conductivity Module and either 3-8050 or 3-8052 to provide sufficient clearance.

## Plug in Modules

Optional modules are available to customize your 9900:

- Relay Module (Panel mount only)
- Direct Conductivity/Resistivity Module
- H COMM Module

All modules come enclosed in a plastic cover. Modules are field installable and replaceable any time.

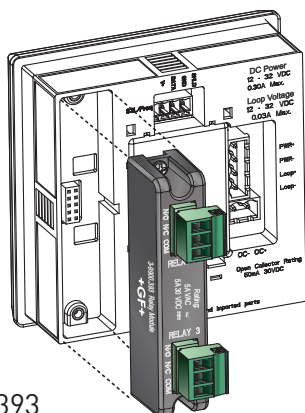

3-9900.393

### Relay Module (Panel Installations only)

Dry-contact relays are electromechanical switches with a moving contact armature. They are suitable for many general purpose applications, AC or DC, including loads up to 250 V. Install RC Filter kits (3-8050.396) on relays used to switch motor or inductive loads.

This module adds two programmable dry-contact relays to the standard Open Collector output in the base unit.

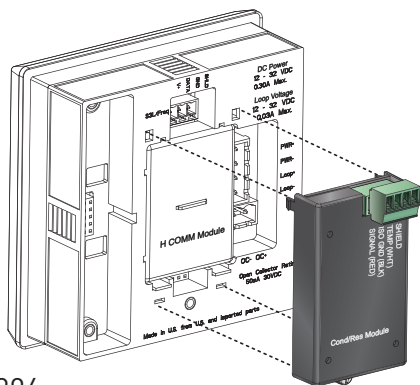

3-9900.394

### Direct Conductivity/Resistivity Module

The Direct Conductivity/Resistivity Module interfaces Signet 2819-2823 and 2839-2842 Conductivity electrodes directly to the 9900. The module also provides filtering and conditioning. (Conductivity/Resistivity and Salinity measurements may also be performed via the 2850 Sensor Electronics connected through the 9900 Digital (S<sup>3</sup>L) inputs.)

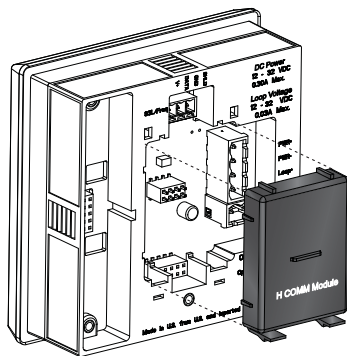

3-9900.395

### H COMM Module (HART®)

The H COMM Module enables communication between the 9900 and a HART®-enabled device. The HART (Highway Addressable Remote Transducer) Protocol superimposes digital signals on top of the 4 to 20 mA analog signal.

Refer to the 9900 H COMM Module Manual 3-9900.094 for further details.

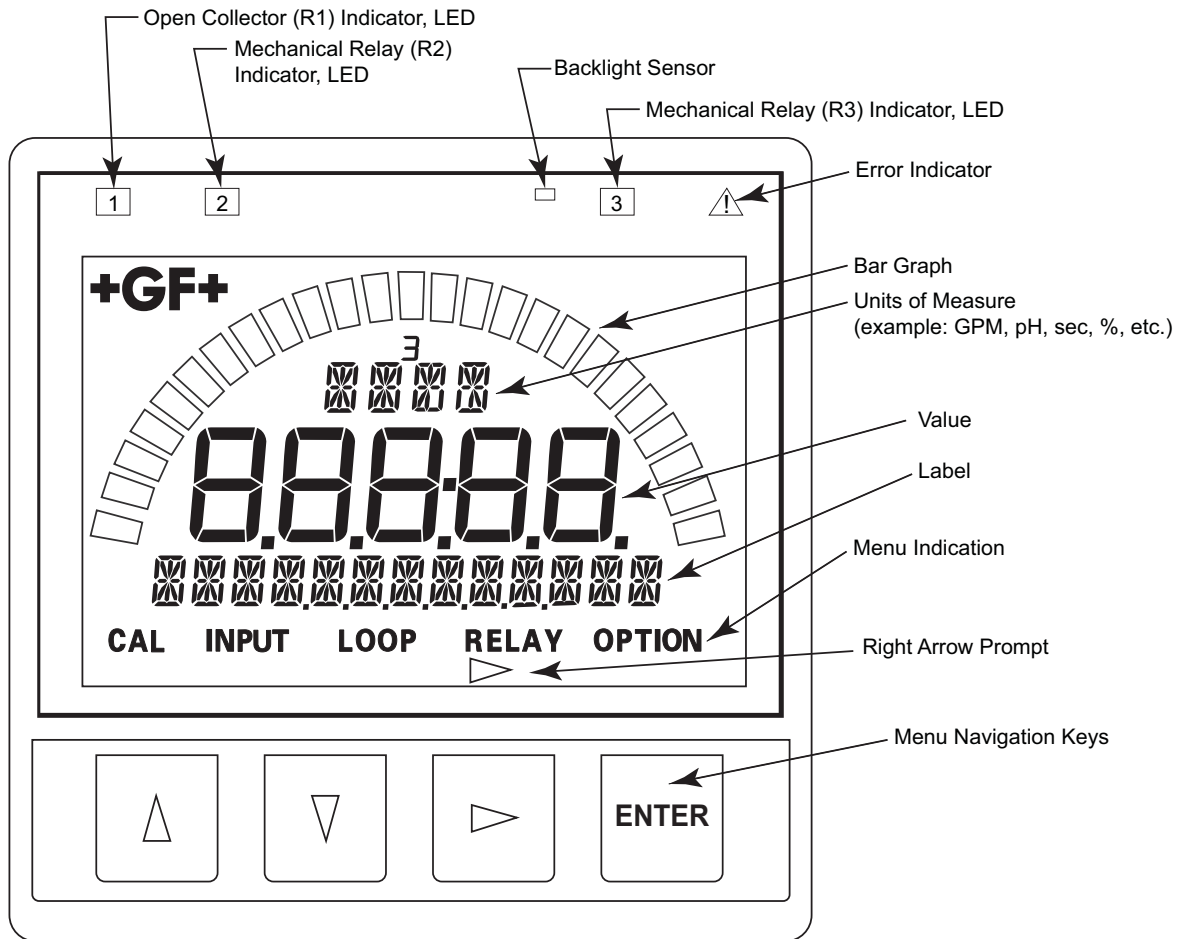

All possible segments shown in this illustration. The instrument's software controls which segments are shown at any particular time. Only the bar graph segment outline and GF logo are visible when the unit is turned off.

The Angle Adjustment Adapter Kit enables the 9900 transmitter to be mounted virtually anywhere. Field Mount Installations with a Conductivity/Resistivity Module require the Angle Adjustment Adapter Kit for wiring clearance.

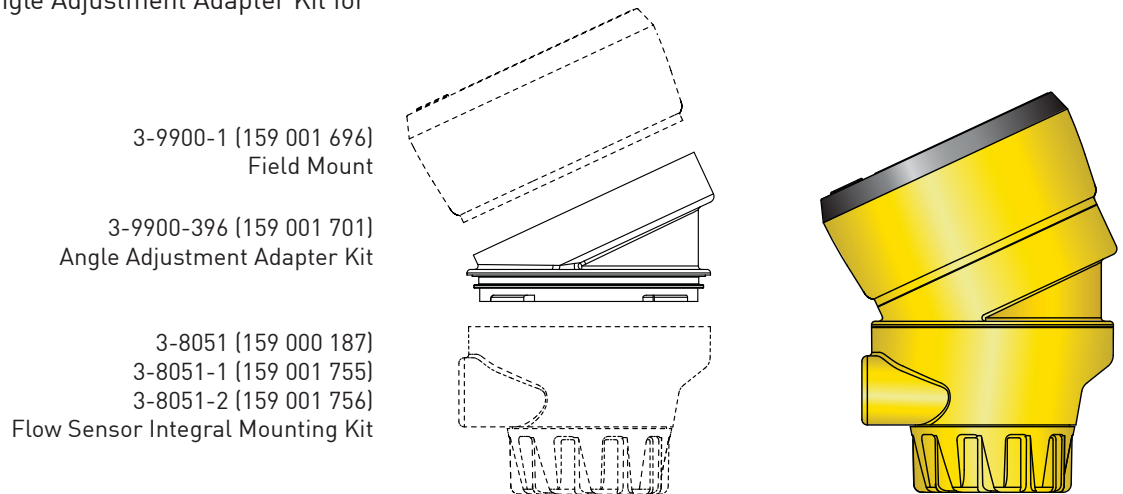

## Ordering Information

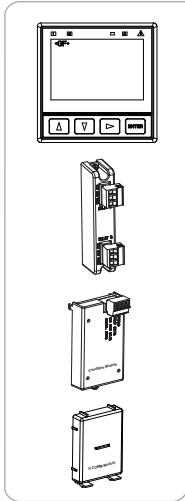

Mfr. Part No	Code	Description
9900 Base Unit - Single Channel, Multi-Parameter, 4 to 20 mA, Open Collector, DC power		
3-9900-1P	<b>159 001 695</b>	9900 Panel Mount Transmitter
3-9900-1	<b>159 001 696</b>	9900 Field Mount Transmitter
Optional Accessory Modules		
3-9900.393	<b>159 001 698</b>	Relay Module - 2 DCR (Dry-contact relays)
3-9900.394	<b>159 001 699</b>	Direct Conductivity/Resistivity Module
3-9900.395	<b>159 001 697</b>	H COMM Module

## Accessories and Replacement Parts

Mfr. Part No	Code	Description
6682-0204	<b>159 001 709</b>	Conductivity Module Plug, 4 Pos, Right Angle
6682-1102	<b>159 001 710</b>	DC Power Plug, 2 Pos, Right Angle
6682-1103	<b>159 001 711</b>	Relay Module Plug, 3 Pos, Right Angle
6682-1104	<b>159 001 712</b>	Loop Power Plug, 4 Pos, Right Angle
6682-3004	<b>159 001 725</b>	Terminal Block Plug
6682-3104	<b>159 001 713</b>	Freq/S <sup>3</sup> L Plug, 4 Pos, Right Angle
7300-7524	<b>159 000 687</b>	24 VDC power supply 7.5 W, 300 mA
7300-1524	<b>159 000 688</b>	24 VDC power supply 15 W, 600 mA
7300-3024	<b>159 000 689</b>	24 VDC power supply 30 W, 1.3 A
7300-5024	<b>159 000 690</b>	24 VDC power supply 50 W, 2.1 A
7300-1024	<b>159 000 691</b>	24 VDC power supply 100 W, 4.2 A
3-0251	<b>159 001 724</b>	PC COMM Configuration Tool
3-8050	<b>159 000 184</b>	Universal Mount Kit
3-8050.396	<b>159 000 617</b>	RC Filter kit (for relay use), 2 per kit
3-8051	<b>159 000 187</b>	Flow Sensor Integral Mounting Kit, NPT, Valox
3-8051-1	<b>159 001 755</b>	Flow Sensor Integral Mounting Kit, NPT, PP
3-8051-2	<b>159 001 756</b>	Flow Sensor Integral Mounting Kit, NPT, PVDF
3-8052	<b>159 000 188</b>	3/4 in. Integral Mount Kit
3-8058-1	<b>159 000 966</b>	I-Go™ Signal Converter, wire-mount
3-8058-2	<b>159 000 967</b>	I-Go™ Signal Converter, DIN rail mount
3-9000.392-1	<b>159 000 839</b>	Liquid Tight Connector Kit, NPT (1 pc.)
3-9900.390	<b>159 001 714</b>	Standard Connector Kit, Right Angle, 9900 Transmitter
3-9900.391	<b>159 001 715</b>	Optional Connector Kit, In-Line, 9900 Transmitter
3-9900.392	<b>159 001 700</b>	Wall Mount Accessory Kit for 9900
3-9900.396	<b>159 001 701</b>	Angle Adjustment Adapter Kit (for Field Mounting)

3-9900.099 Rev D (10/12)

© Georg Fischer Signet LLC

3401 Aero Jet Avenue, El Monte, CA 91731-2882 U.S.A. • Tel. (626) 571-2770 • Fax (626) 573-2057 • www.gfsignet.com • e-mail: signet.ps@georgfischer.com  
 Specifications subject to change without notice. All rights reserved. All corporate names and trademarks stated herein are the property of their respective companies.